

# Opal Matte Black 400ml Liquid Soap Dispenser

Opal<sup>®</sup>  
Range



## Part Number 400SD-LBK

UK Manufactured in zinc coated steel  
High quality, durable refillable soap dispenser  
400ml capacity, removable liquid pump reservoir  
Contemporary matte black finish - RAL 9005  
Resist of fingerprints, simple to clean and maintain  
Front window to check stock levels  
Key lockable with low profile chrome lock  
Fixing kit and key provided

*The Opal Range is an official Made In Britain product*

Height 202mm  
Width 95mm  
Projection 98mm



## Dimensions

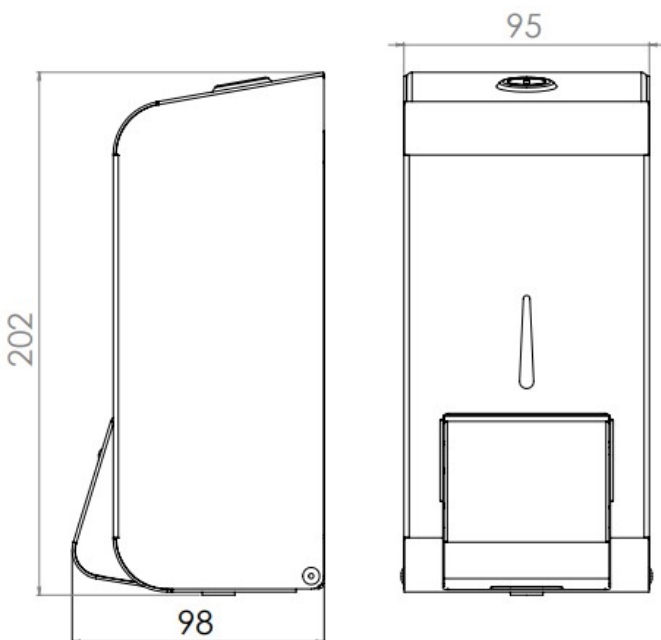

LIQUID  
PUMP



400ML  
REFILL



## Suitability

Flowable liquid soap, cream, gel, disinfectant  
Liquid pump standard (2ml Shot) - 1m available

### Available Spare Parts

**4MR** Reservoir, **4MP-L** Pump, **5099** lock + key

**Note** The Opal foam soap dispenser is designed for conversion. Additional foam or spray pumps are also available. **Part No 4MF- / 4MP-S**